

RF-3

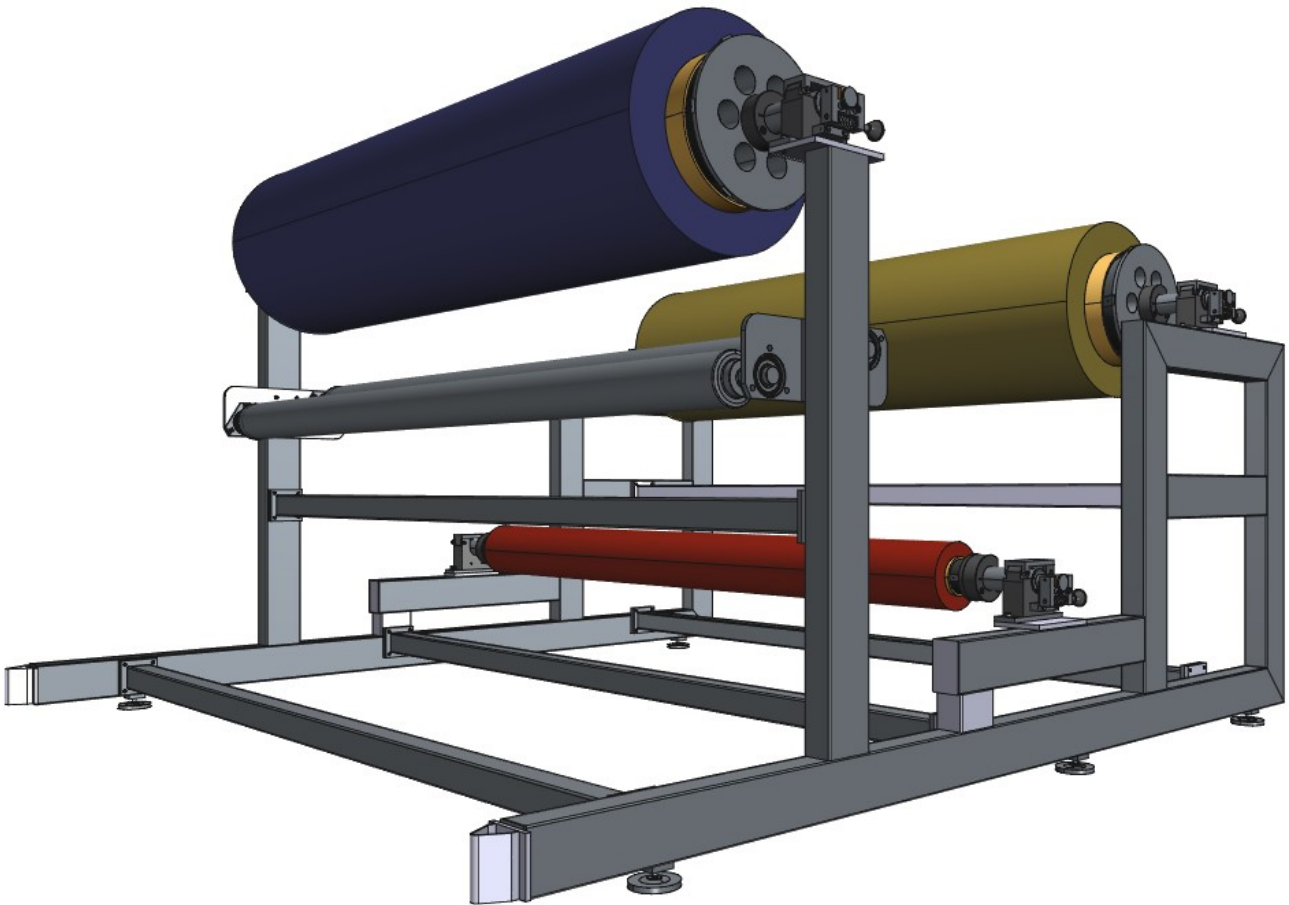

THE AUTEX FEEDER RF-3 MULTIPLE ROLL FEEDER IS AN UNWINDING UNIT THAT MOUNTS 3 INDEPENDENT PASSIVE ROLL BARS, ALLOWING THE USE OF ANY OF THE 3 ROLLS AT ANY TIME.



RF-3

The **Autex Feeder RF-3** is an unwinding unit designed to unwind rolls of material. The RF-2 multiple roll feeder is an unwinding unit that mounts 3 independent passive roll bars, allowing the use of any of the 3 rolls at any time. Each roll bar incorporates an adjustable brake and a set of cones tailored to the customer's required size.

TECHNICALS CHARACTERISTICS

- **Width:** Required width = 2295 mm + 1200 mm (machine width + safety zone)
- **Length:** Required length = 2400 mm + 600 mm (machine length + safety zone)
- **Height:** Height with 70 cm diameter roll: 1560 mm.
- **Floor requirements:**
 - The leveling tolerance for the installation location is ± 1 cm: Slope of less than 1%.
 - Floor smoothness: Maximum rise-fall distance: 40 mm.

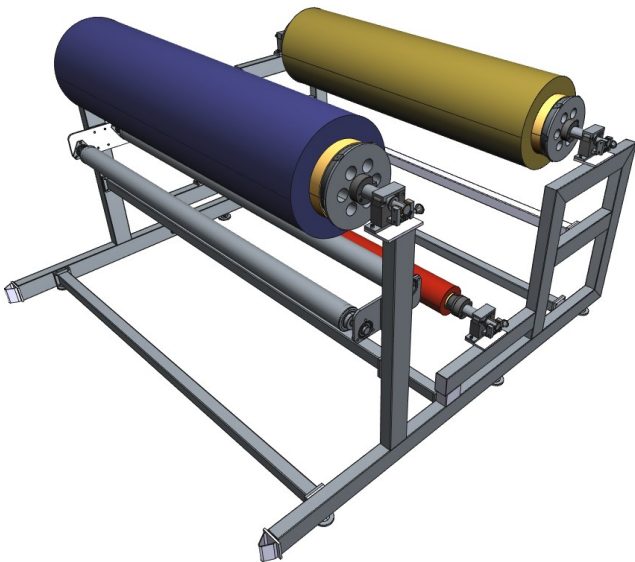

Overview of the Autex Feeder RF-3

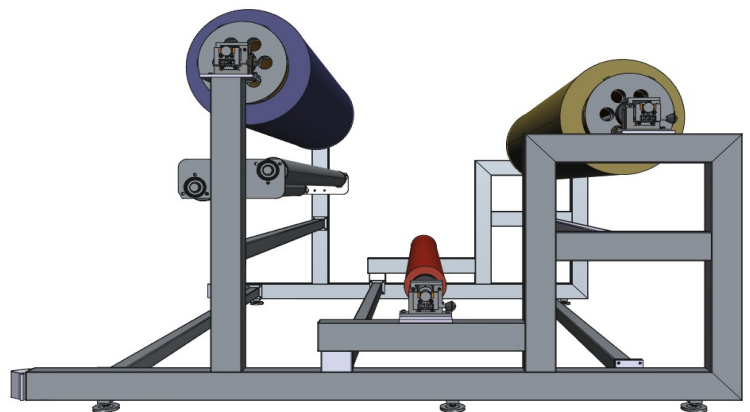

Autex Feeder RF-3 Fabric Threading



C/Can Negoci, 18 - P.I. Can Negoci
08310 Argentona - Barcelona – Spain
Telephone: 0034 93 7589325
ventas@autex-int.com – www.autex-int.com